

**SPEC SHEET**

**8' STANDARD PERFORATED BENCH W BACK IN-GROUND**

**Wt. 190 lbs**

*photo*

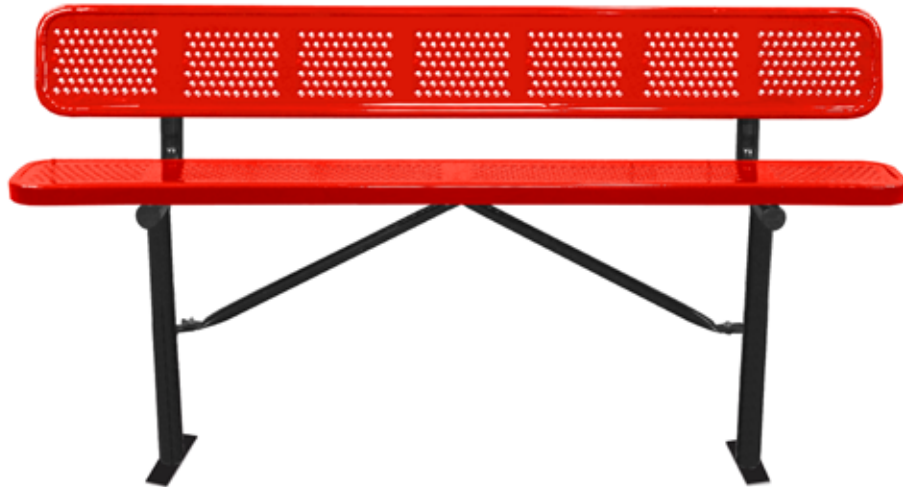

*top view*

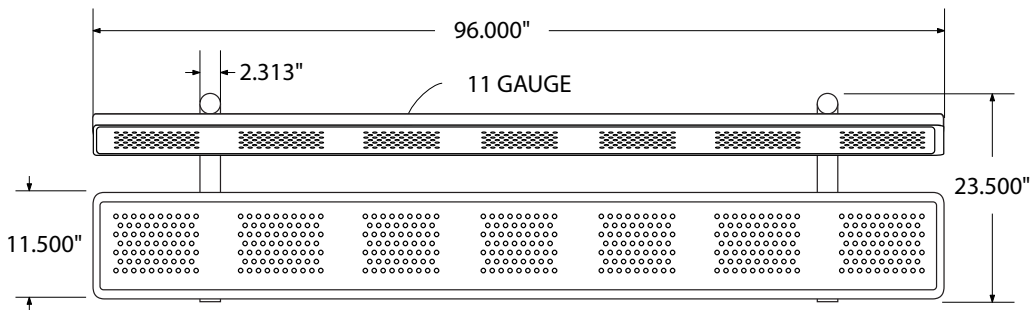

*front*

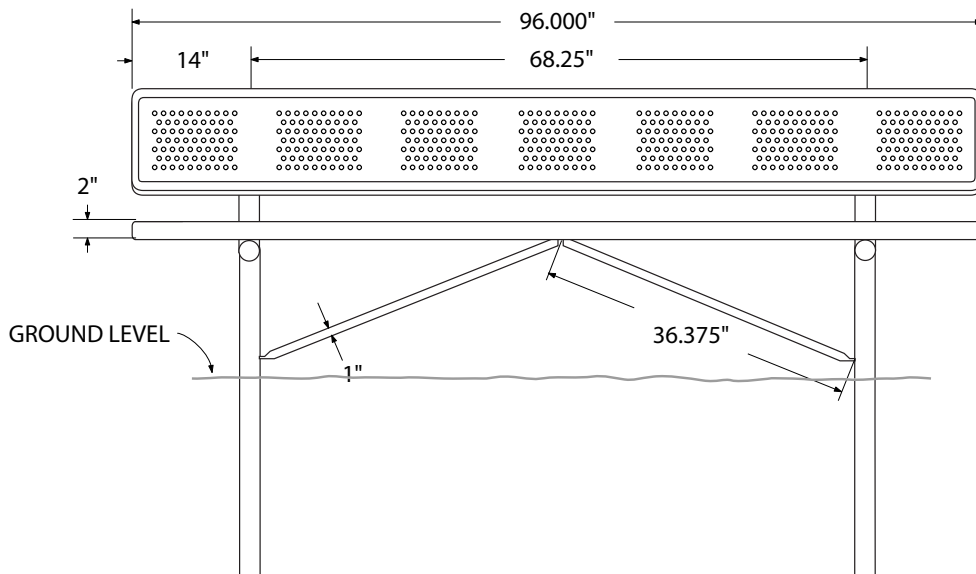

**side view**

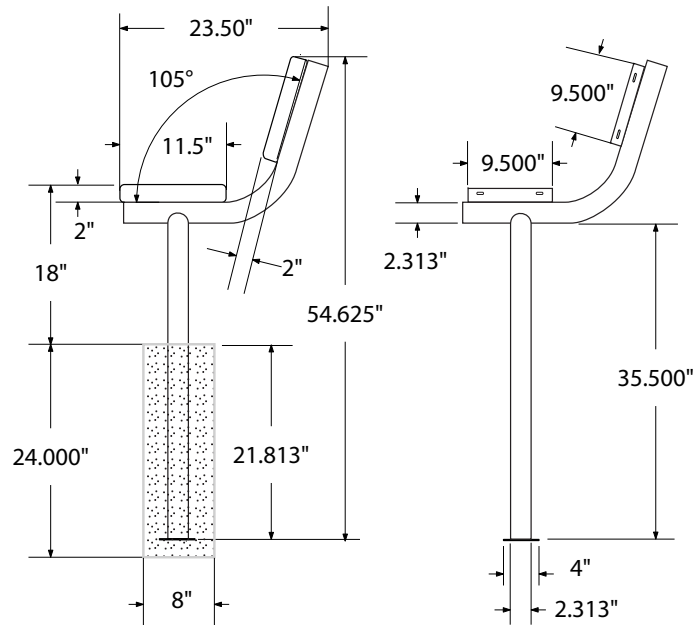

**product finish**



The functional surfaces of our furniture are covered in a copolymer-based thermoplastic powder coating. Thermoplastic is environmentally safe, the coating will never fade, crack, peel, warp, or discolor for the life of the product. Thermoplastic is applied at a thickness of 25-30 mils.



Tubular legs and understructure parts are made from galvanized steel and are finished with black polyester powder coating.

**mounting types**

P = Portable : no mount

SM = Surface Mount:  
concrete anchors  
through discs welded  
to legs

IG= In-Ground:  
J-rods set in concrete  
through discs welded  
to legs

IG= In-Ground  
2 nd option extra  
long legs

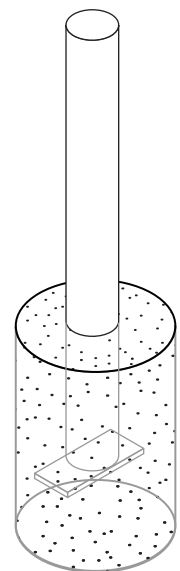
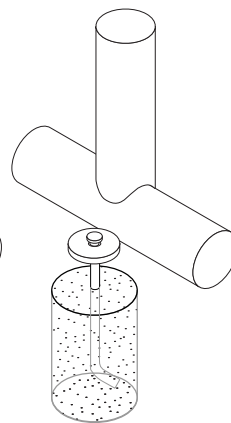
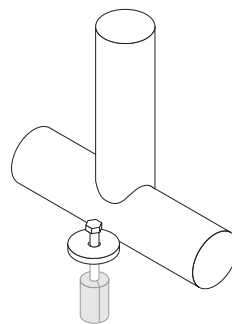
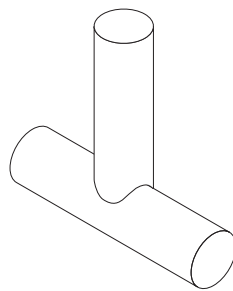

PORTABLE

SURFACE MOUNT

IN-GROUND

IN-GROUND