

## Perforated Metal Backless Park Bench

SKU:

---

4' CF-D6EUS      6' CF-2LWRS  
8' CF-IKPVC      10' CF-LHS7Z  
15' CF-KWWQD



### Product maintenance

Inspect all hardware and fasteners, regularly check that all nuts and bolts are secure. Periodically examine for any signs of vandalism on any of your products thermoplastic surfaces. If any thermoplastic surface is vandalized by spray paint, simple take a rag and a aerosol can of WD40 ® and wipe the spray paint off. If the thermoplastic surface has any cuts simple take an industrial heat gun to the affected area. For regular cleaning use soap and water.

### Thermoplastic Coating

Our outdoor furniture is covered in a copolymer-based thermoplastic powder coating. Thermoplastic is environmentally safe, the coating will never fade, crack, peel, warp, or discolor for the life of the product. Thermoplastic has the best adhesion rate of any other process. This keeps the metal base free of any corrosion possibilities. Thermoplastic is applied at a thickness of 25-30 mils. This allows maximum protection with the best possible surface. Thermoplastic can be easily repaired. Cuts are repaired by heating the affected area with an industrial heat gun. The thermoplastic will rebound itself. The properties of thermoplastic also make spray painting difficult for vandals. Simply wash product with a standard industrial cleaner.

### Specifications

#### General

All seats and backs of the listed products above are protected with Thermoplastic coating. Black powder coated galvanized steel legs and support structure. Available in expanded metal and perforated metals seats and backs. Personalization is also available.

Check for any damaged or missing parts of if you have problems assembling your furniture / equipment please call our Customer Service Representatives.



# Standard Metal Bench with Back

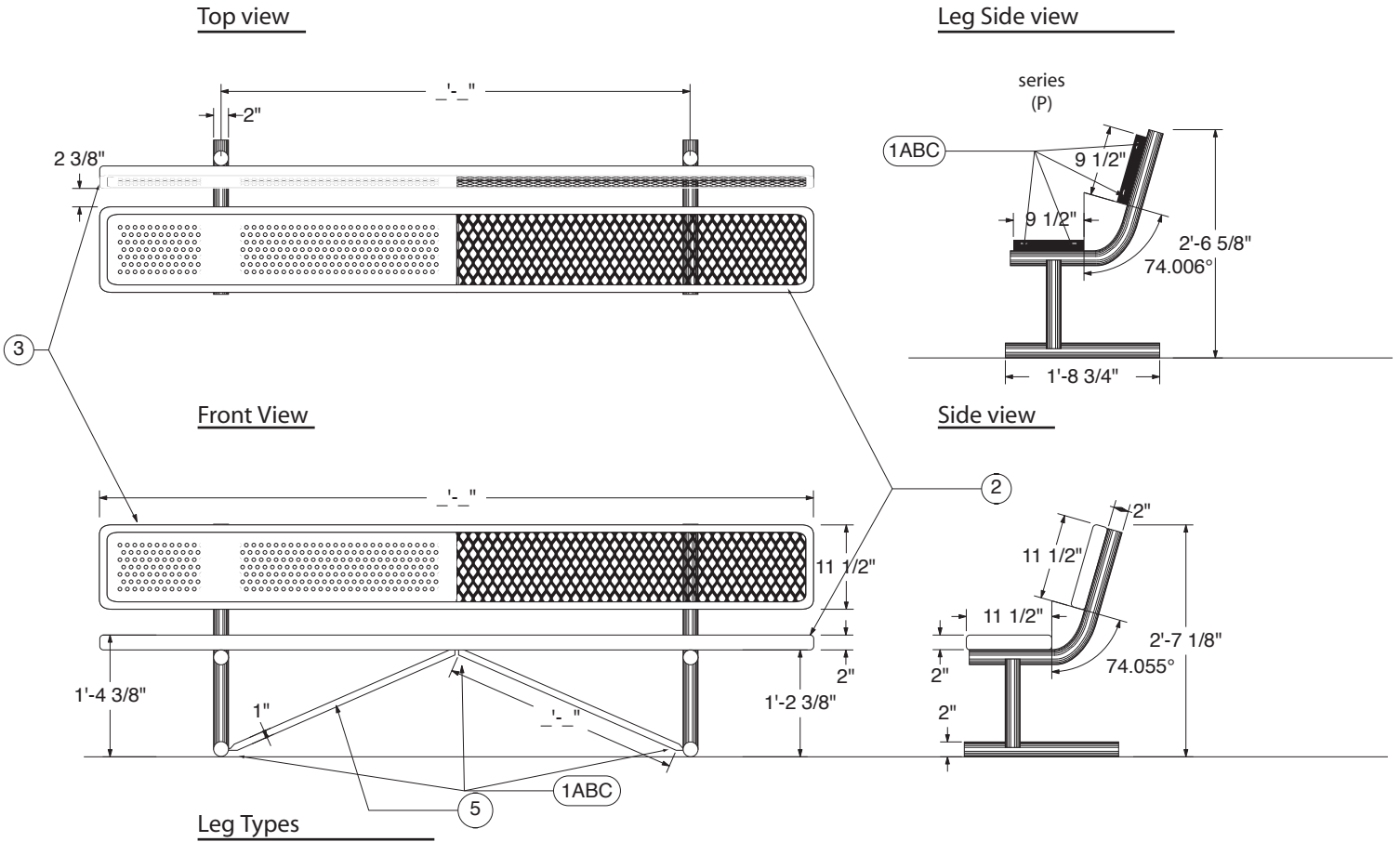

Front View

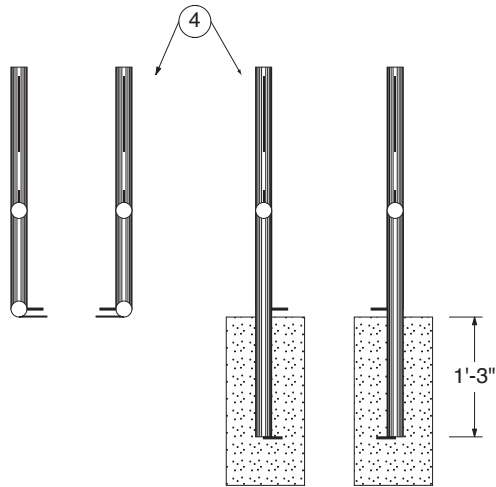

Top view

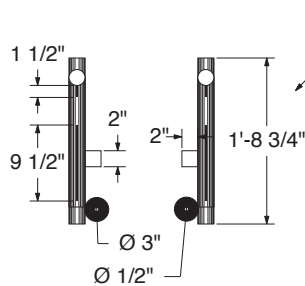

Side view

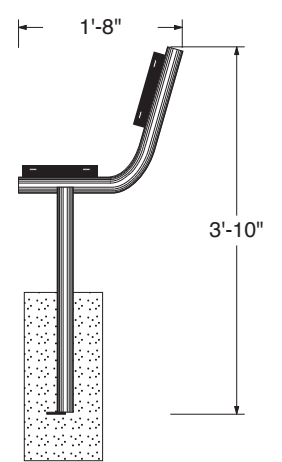

Available Styles



Expanded Metal

Perforated Metal

Quantities (per bench)

1A - 5/16" Hex head bolts	- qty 11
1B - 5/16" Washer	- qty 22
1C - 5/16" Nut	- qty 11
2 - Bench seat	- qty 1
3 - Bench back	- qty 1
4 - Leg Types (per bench)	- qty 2
5 - Cross braces	- qty 2

Hardware

(A) 5/16" Hex head bolt	
(B) 5/16" Washer	
(C) 5/16" Nut	

scale 1/2" = 1'

# Standard Metal Bench w/o Back

Top view

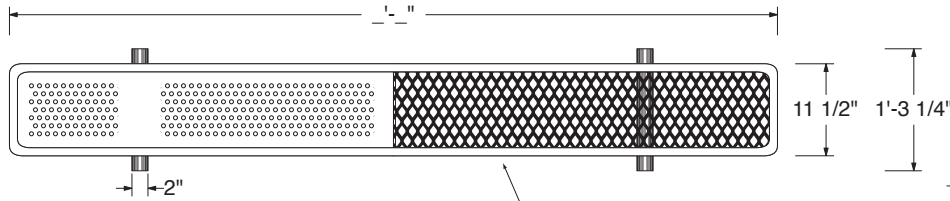

Seat Side view

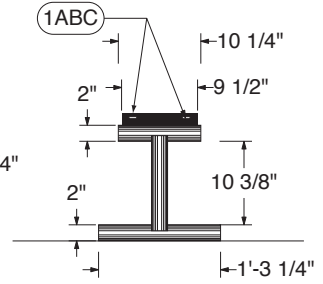

Front View

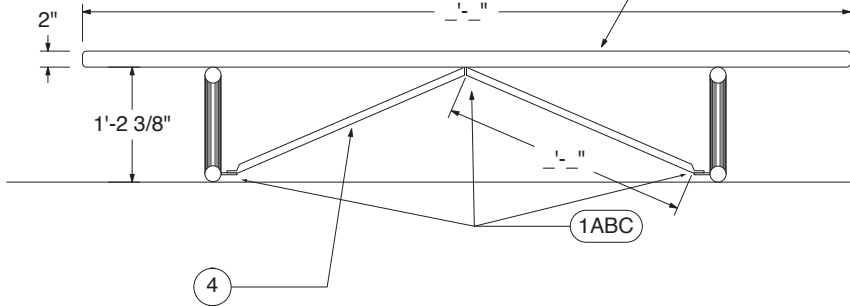

Side view

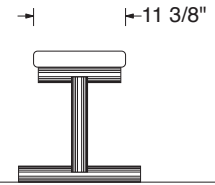

Front View

Top view

Side view

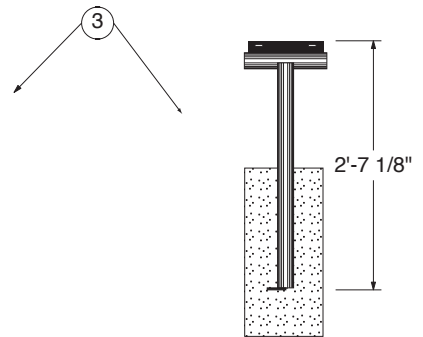
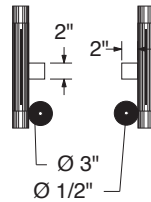
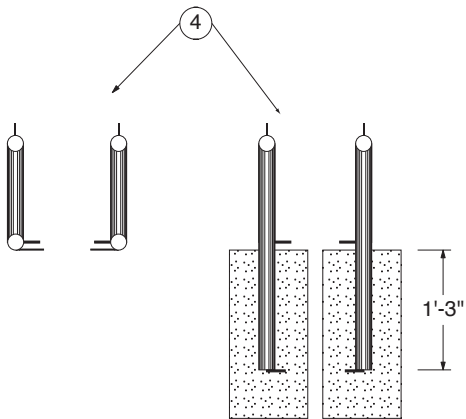

Available Styles



Expanded Metal



Perforated Metal

Quantities (per bench)

- 1A - 5/16" Hex head bolts - qty 7
- 1B - 5/16" Washer - qty 14
- 1C - 5/16" Nut - qty 7
- 2 - Bench seat - qty 1
- 3 - Leg Types (per bench) - qty 2
- 4 - Cross Braces - qty 2

Hardware

(A) 5/16" Hex head bolt



(B) 5/16" Washer



(C) 5/16" Nut



scale 1/2" = 1'



# Assembly Instructions

Standard Expanded Metal - w/o Back

Standard Expanded Metal w/Back

Expanded metal Player's Bench w/Back  
Personalized Expanded Metal Bench

Standard Perforated Metal - w/o Back

Standard Perforated Metal w/Back

Perforated metal Player's Bench w/Back

Personalized Perforated Metal Bench

Note: Work 1 one side at a time.

Do not tightly secure bolts until product is fully assembled.

## Step 1:

Check that all hardware, legs, and seats are accounted for. Total parts for the assembly of one bench with back two legs (SM or IG or P), two seats, two brace rod, eleven 5/16" Hex Head Bolts, nuts, and twenty two washers.

Total parts for the assembly of one bench with out back two legs (SM or IG or P), one seat, two brace rod, seven 5/16" Hex Head Bolts, nuts, and fourteen washers.

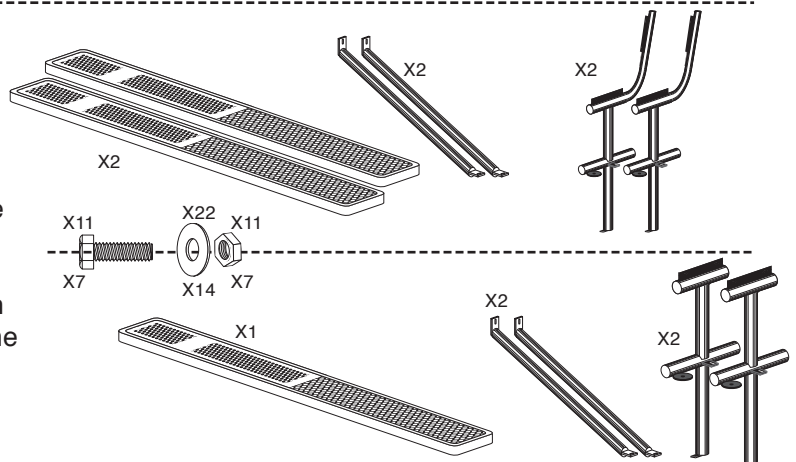

## Step 2A:

Assembly of all benches with backs are the same. Take one of the legs and stand it up right, then take the seat and rest it on the the leg (make sure that the leg is on the outside of the bench attachment.) With out tightening any of the bolts, continue onto the other leg and attach the bolts at the top of the leg. Now lay down the bench on its back. Now grab the back and lay it on the legs, then attach the bolts. Put the bench back up right and then attach the two leg braces, start with one side by attaching the bolt at the bace of the leg then for the first leg slide the bolt thought the hole where the brace meets teh seat. Now take the second brace and attach the bolt to the leg and to the bolt that is holding the first brace.

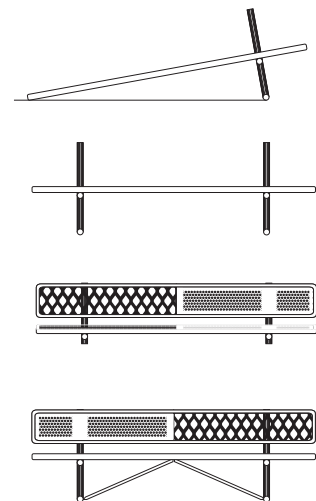

*(To prevent damage to your bench  
place a blanket underneath the bench.)*

# Assembly Instructions

---

Standard Expanded Metal - w/o Back

Standard Expanded Metal w/Back

Expanded metal Player's Bench w/Back

Personalized Expanded Metal Bench

Standard Perforated Metal - w/o Back

Standard Perforated Metal w/Back

Perforated metal Player's Bench w/Back

Personalized Perforated Metal Bench

## Assembly continuation

---

### Step 2B:

Assembly of all benches with out backs are the same. Take the seat and flip it over then take one of the leg (make sure that the leg is on the outside of the bench attachment) and attach it to the seat. With out tightening any of the bolts, continue onto the other leg and attach the bolts at the top of the leg. Put the bench back up right and then attach the two leg braces, start with one side by attaching the bolt at the base of the leg then for the first leg slide the bolt through the hole where the brace meets the seat. Now take the second brace and attach the bolt to the leg and to the bolt that is holding the first brace.

*(To prevent damage to your bench place a blanket underneath the bench.)*

---

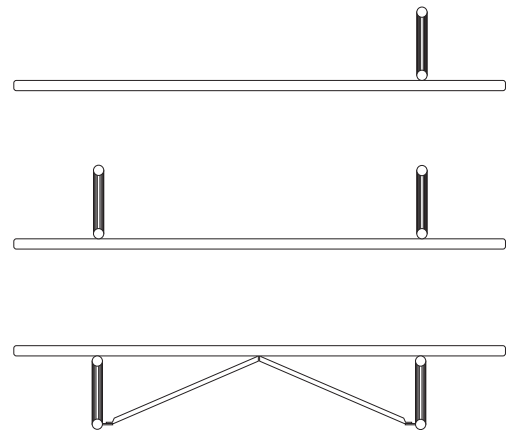

### Step 3:

After all bolts are in place flip bench on its feet. Then make sure the bench is level before tightening all of the bolts in the same progression that you started with. After all bolts are tightened enjoy your new bench.

