

Commercial Perforated Roll-Formed Park Bench

SKU:

4' CF-GDF8V



Product maintenance

Inspect all hardware and fasteners, regularly check that all nuts and bolts are secure. Periodically examine for any signs of vandalism on any of your products thermoplastic surfaces. If any thermoplastic surface is vandalized by spray paint, simple take a rag and a aerosol can of WD40 ® and wipe the spray paint off. If the thermoplastic surface has any cuts simple take an industrial heat gun to the affected area. For regular cleaning use soap and water.

Thermoplastic Coating

Our outdoor furniture is covered in a copolymer-based thermoplastic powder coating. Thermoplastic is environmentally safe, the coating will never fade, crack, peel, warp, or discolor for the life of the product. Thermoplastic has the best adhesion rate of any other process. This keeps the metal base free of any corrosion possibilities. Thermoplastic is applied at a thickness of 25-30 mills. This allows maximum protection with the best possible surface. Thermoplastic can be easily repaired. Cuts are repaired by heating the affected area with an industrial heat gun. The thermoplastic will rebound itself. The properties of thermoplastic also make spray painting difficult for vandals. Simply wash product with a standard industrial cleaner.

Specifications

General

All of the listed products above are protected with Thermoplastic coating. Predrilled holes for surface mounting. Cast iron legs. Signature series customized benches have four optional areas for text and graphics.

Diamond Pattern Bench W/out Back

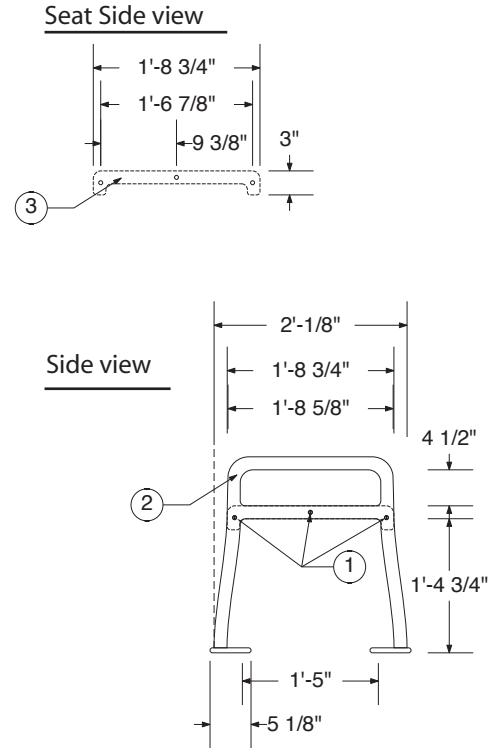
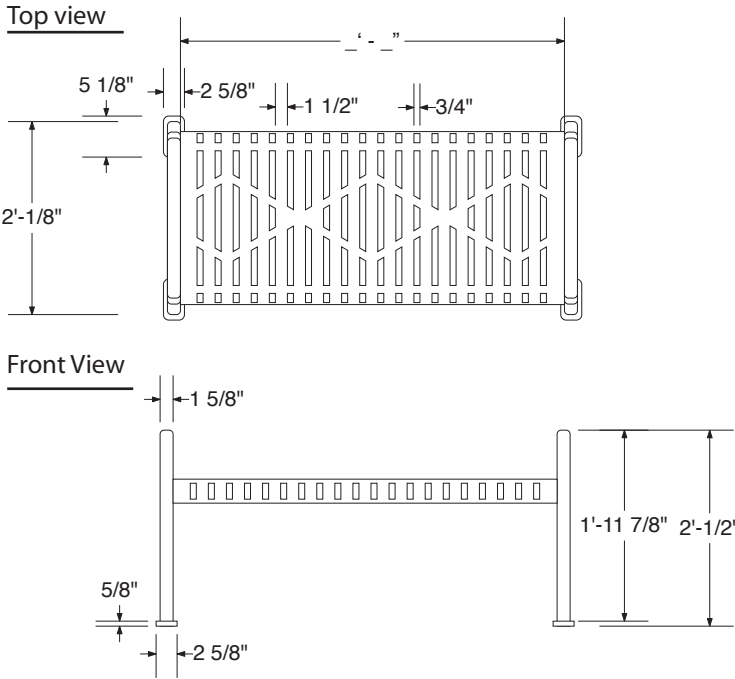



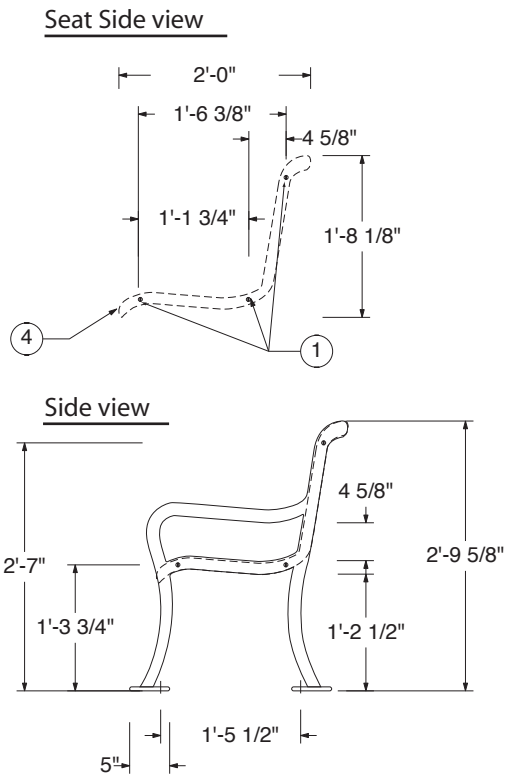
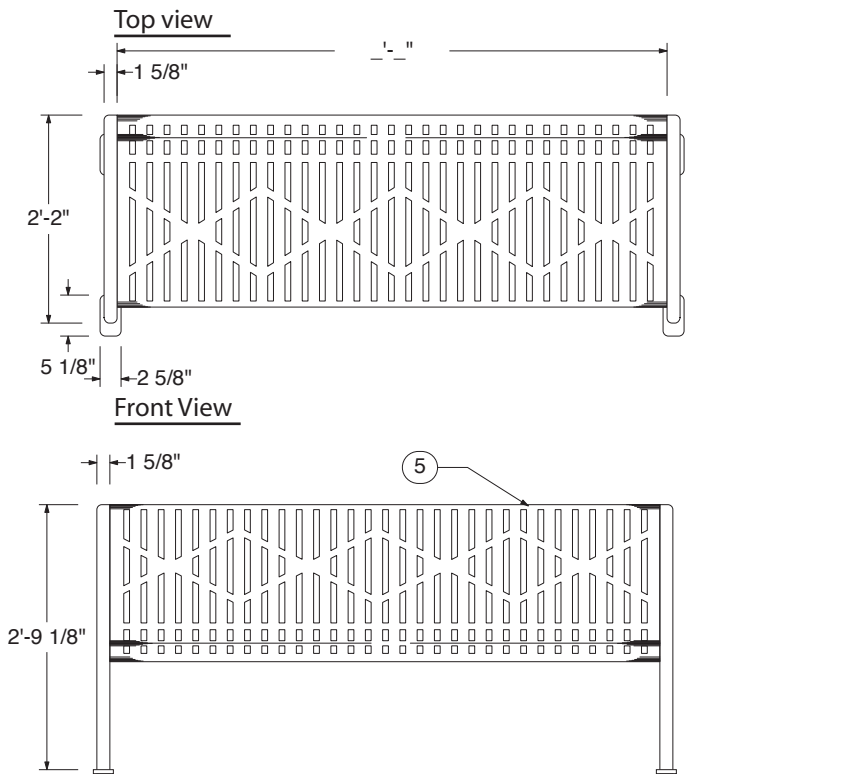



Roll Formed Bench (Diamond, Perforated, Signature Series)



Available Styles

Quantities (per bench)

Hardware

	Diamond	1A - Machine Bolt - qty 6	
		1B - 5/16" Washer - qty 6	
		1C - 5/16" Nut - qty 6	
	Perforated	2 - Cast Steel Bench Leg w/o Back - qty 2	
		3 - 11 Gage Steel Bench Seat w/o Back - qty 1	
		4 - Cast Steel Bench Leg with Back - qty 2	
		5 - 11 Gage Steel Bench Seat with Back - qty 1	
	Wire		
			(A) 5/16" Machine head 
			(B) 5/16" Washer 
			(C) 5/16" Nut 

scale 1/2" = 1'



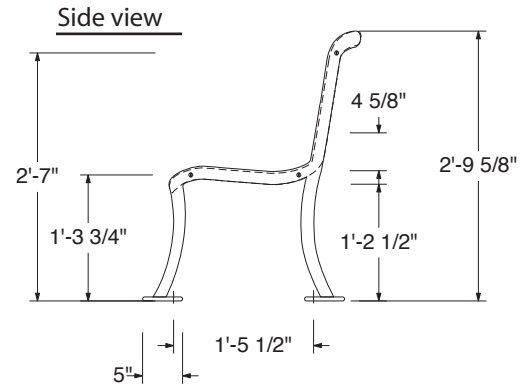
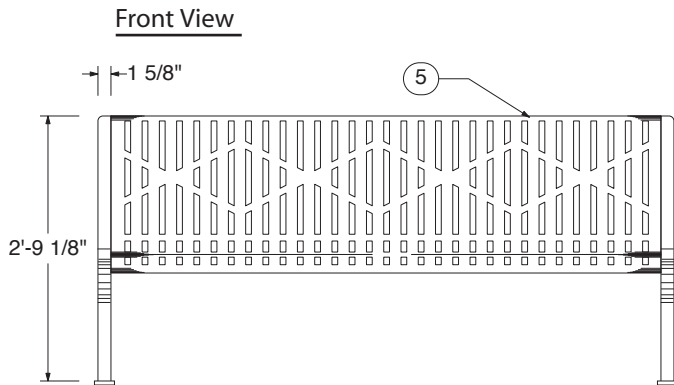
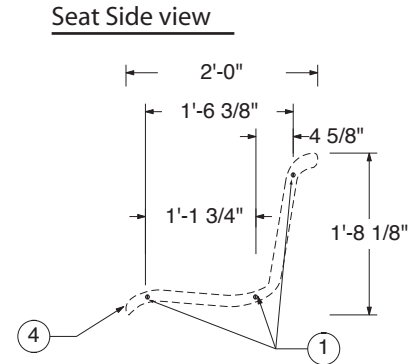
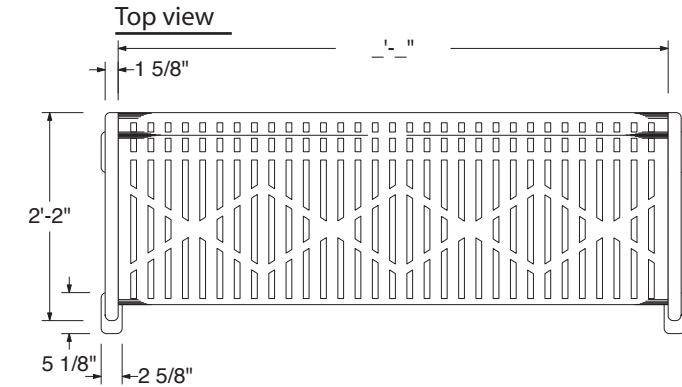

Armless Roll Formed Diamond Bench



Available Styles

Quantities (per bench)

Hardware

Available Styles	Quantities (per bench)	Hardware
 Diamond	1A - Machine Bolt - qty 6	(A) 5/16" Machine head  (B) 5/16" Washer  (C) 5/16" Nut 
	1B - 5/16" Washer - qty 6	
	1C - 5/16" Nut - qty 6	
	2 - Cast Steel Bench Leg w/o Back - qty 2	
	3 - 11 Gage Steel Bench Seat w/o Back - qty 1	
4 - Cast Steel Bench Leg with Back - qty 2		
5 - 11 Gage Steel Bench Seat with Back - qty 1		

scale 1/2" = 1'

Assembly Instructions

Roll Formed Bench
Signature Series Customized Benches
Diamond Pattern Bench W/out Back
Roll Formed Perforated Bench
Rolled Wire Bench

Note: Work 1 one side at a time.

Do not tightly secure bolts until product is fully assembled.

Step 1:

Check that all hardware, legs, and seats are accounted for. Total parts for the assembly of one bench with or with out a back equals two legs, one seat, six 5/16" machine bolts, six 5/16" washers, and six 5/16" nuts.

(for all benches the washer is placed on the inside of the bench between the nut and the legs.)

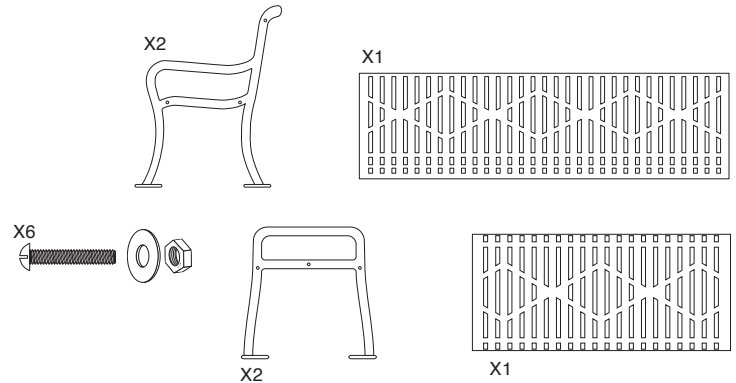

Step 2A:

Place Bench with back on its back side and start by attaching the first leg at the top of the seat. With out tightening any of the bolts move to the seat bottom back bolt them the bottom front bolt. Repeat with other leg.

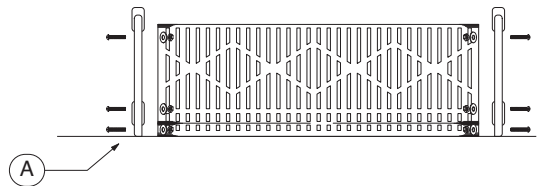

Step 2B:

Prop Bench with out back seat down and start by attaching the first leg at the middle of the seat. With out tightening any of the bolts move to the other two bolt. Repeat with other leg.

(To prevent damage to your bench place a blanket underneath the bench.)

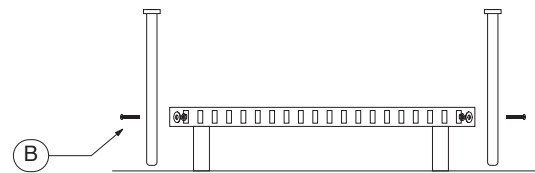

Step 3:

After all bolts are in place flip bench on its feet. Then Tighten all of the bolts in the same progression that you started with. After all bolts are tightened enjoy your new bench.

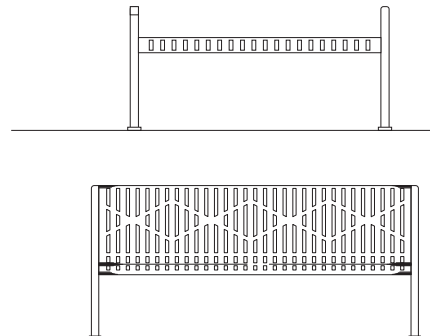

Assembly Instructions

Armless Roll Formed Diamond Bench

Note: Work 1 one side at a time.

Do not tightly secure bolts until product is fully assembled.

Step 1:

Check that all hardware, legs, and seats are accounted for. Total parts for the assembly of one bench with or without a back equals two legs, one seat, six 5/16" machine bolts, six 5/16" washers, and six 5/16" nuts.

(for all benches the washer is placed on the inside of the bench between the nut and the legs.)

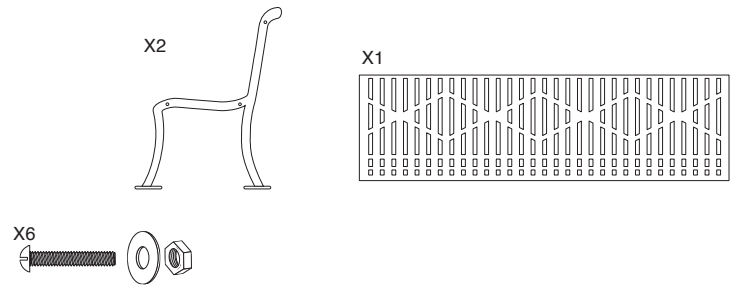

Step 2:

Place Bench with back on its back side and start by attaching the first leg at the top of the seat. Without tightening any of the bolts move to the seat bottom back bolt then the bottom front bolt. Repeat with other leg.

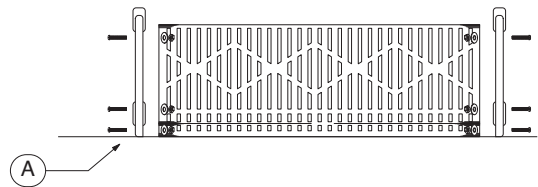

(To prevent damage to your bench place a blanket underneath the bench.)

Step 3:

After all bolts are in place flip bench on its feet. Then Tighten all of the bolts in the same progression that you started with. After all bolts are tightened enjoy your new bench.

