

## Backless Slatted Metal Commercial Park Bench

SKU:

---

4' CF-K3ZPX      6' CF-A6QIN

8' CF-QCCP8



### Product maintenance

Inspect all hardware and fasteners, regularly check that all nuts and bolts are secure. Periodically examine for any signs of vandalism on any of your products thermoplastic surfaces. If any thermoplastic surface is vandalized by spray paint, simply take a rag and a aerosol can of WD40 ® and wipe the spray paint off. If the thermoplastic surface has any cuts simply take an industrial heat gun to the affected area. For regular cleaning use soap and water.

### Thermoplastic Coating

Our outdoor furniture is covered in a copolymer-based thermoplastic powder coating. Thermoplastic is environmentally safe, the coating will never fade, crack, peel, warp, or discolor for the life of the product. Thermoplastic has the best adhesion rate of any other process. This keeps the metal base free of any corrosion possibilities. Thermoplastic is applied at a thickness of 25-30 mills. This allows maximum protection with the best possible surface. Thermoplastic can be easily repaired. Cuts are repaired by heating the affected area with an industrial heat gun. The thermoplastic will rebound itself. The properties of thermoplastic also make spray painting difficult for vandals. Simply wash product with a standard industrial cleaner.

### Specifications

#### General

Slatted bench seat of the listed products above are protected with Thermoplastic coating. Black powder coated galvanized steel legs and support structure. Solid 11 gauge steel.

Check for any damaged or missing parts of if you have problems assembling your furniture / equipment please call our Customer Service Representatives.



# Slatted Bench

Top view

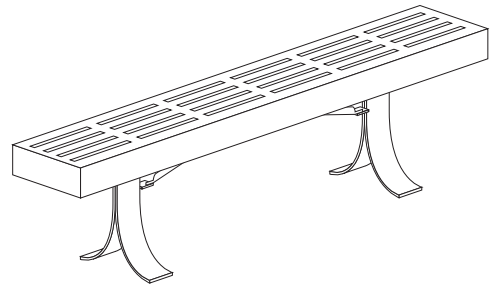
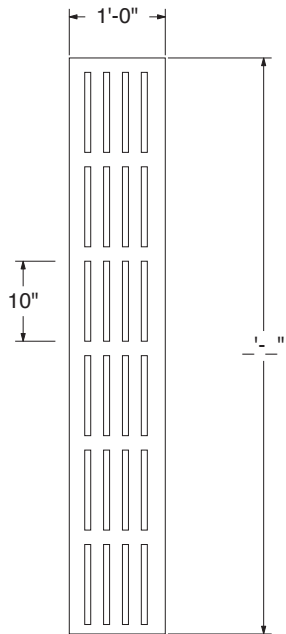

Seat Side view

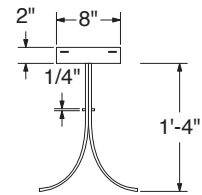

Front View

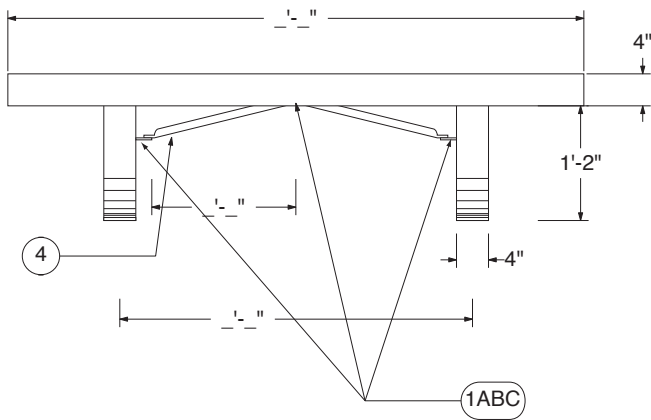

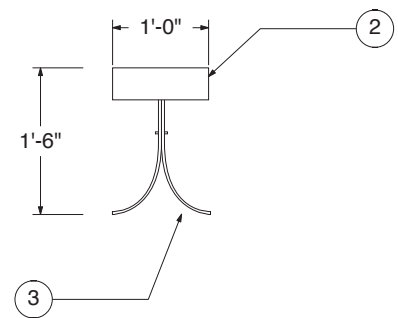

Side view



**Available Styles**

**Quantities (per bench)**

**Hardware**

	<p>Pre cut Bench Slats</p>	<p>1A - 5/16" Hex head bolts - qty 7            1B - 5/16" Washer - qty 14            1C - 5/16" Nut - qty 7            2 - Bench Seat - qty 1            3 - Leg Types (per bench) - qty 2            4 - Leg Supports - qty 2</p>	<p>Ⓐ 5/16" Hex head bolt             Ⓑ 5/16" Washer             Ⓒ 5/16" Nut </p>
--	----------------------------	---	---

scale 1/2" = 1'

# Assembly Instructions

---

## Slatted Bench

Note: Work 1 one side at a time.

Do not tightly secure bolts until product is fully assembled.

---

### Step 1:

Check that all hardware, legs, and bench is accounted for. Total parts for the assembly of one slatted bench. Two legs, one seat, two brace rod, seven 5/16" Hex Head Bolts, nuts, and fourteen washers.

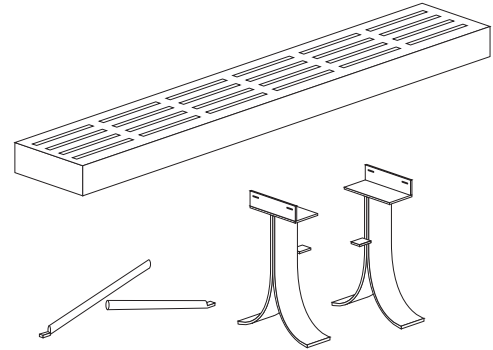

### Step 2:

Assembly of all slatted benches are the same. Take the bench seat and flip it over then take one of the leg (make sure that the leg is on the outside of the bench attachment) and attach it to the bench seat. With out tightening any of the bolts, continue onto the other leg and attach the bolts at the top of the leg. Next attach the two center braces to the under structure of the bench.

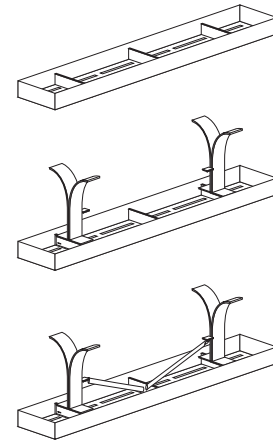

*(To prevent damage to your bench place a blanket underneath the bench.)*

---

### Step 3:

After all bolts are in place, make sure the bench is level before tightening all of the bolts in the same progression that you started with. After all bolts are tightened enjoy your new bench.

