

Commercial U-Leg Wire Bench Without Back

SKU:

4' CF-6JVQE 6' CF-FMZXB

8' CF-PEZNT



Thermoplastic Coating

Our outdoor furniture is covered in a copolymer-based thermoplastic powder coating. Thermoplastic is environmentally safe, the coating will never fade, crack, peel, warp, or discolor for the life of the product. Thermoplastic has the best adhesion rate of any other process. This keeps the metal base free of any corrosion possibilities. Thermoplastic is applied at a thickness of 25-30 mils. This allows maximum protection with the best possible surface. Thermoplastic can be easily repaired. Cuts are repaired by heating the affected area with an industrial heat gun. The thermoplastic will rebind itself. The properties of thermoplastic also make spray painting difficult for vandals. Simply wash product with a standard industrial cleaner.

Specifications

General

All of the listed products above are protected with Thermoplastic coating. Predrilled holes for surface mounting. Cast iron legs. Signature series customized benches have four optional areas for text and graphics.



Roll Formed Bench (Wire, Perforated)

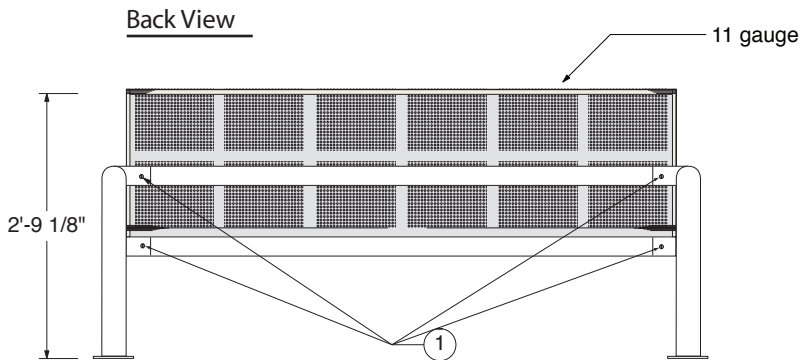
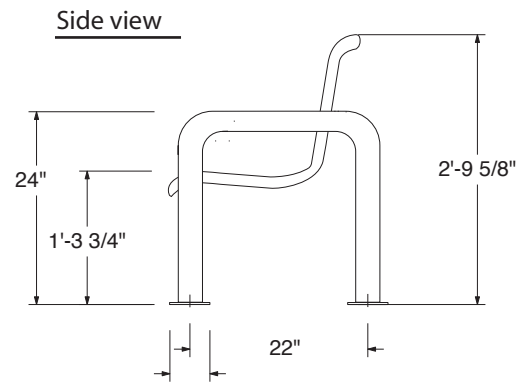
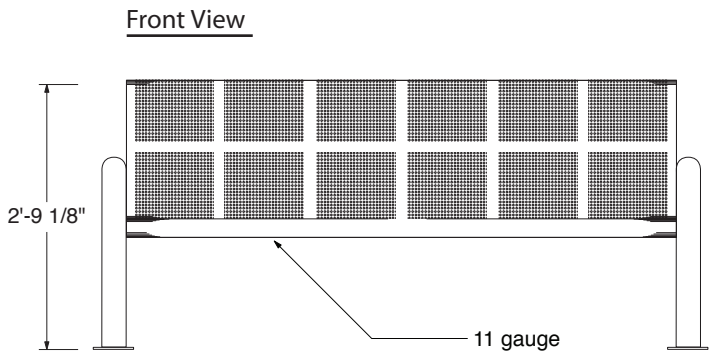
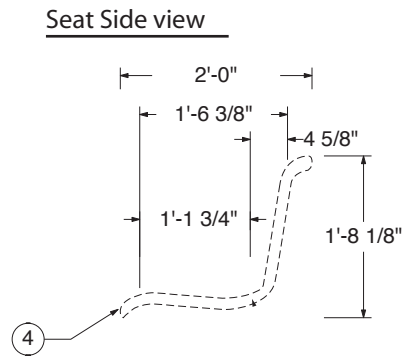
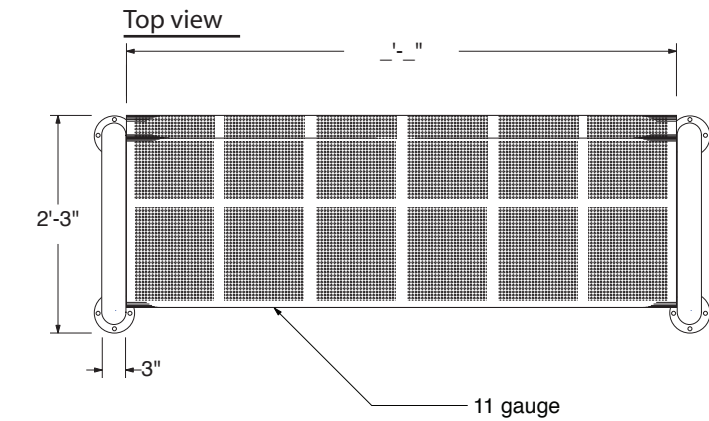

Available Styles

Quantities (per bench)

Hardware

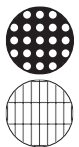

Perforated



Wire

- | | |
|-------------------------------------|---------|
| 1A - Machine Bolt | - qty 4 |
| 1B - 5/16" Washer | - qty 4 |
| 1C - 5/16" Nut | - qty 4 |
| 2 - Steel Bench Leg w/o Back | - qty 2 |
| 3 - 11 Gage Steel Bench Seat w Back | - qty 1 |
| 4 - Steel Bench Leg bar | - qty 2 |

Ⓐ 5/16" Machine head 

Ⓑ 5/16" Washer 

Ⓒ 5/16" Nut 

scale 1/2" = 1'

Roll Formed Bench without Back (Perforated, Expanded, Wire)

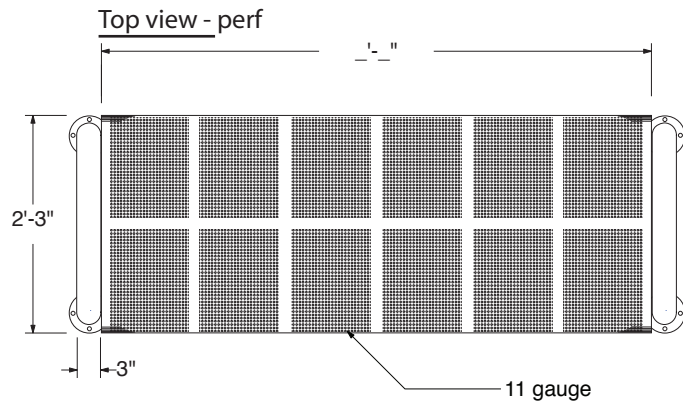

Seat Side view

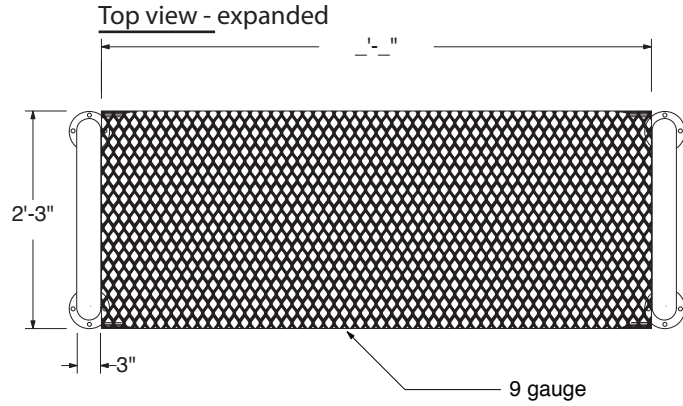
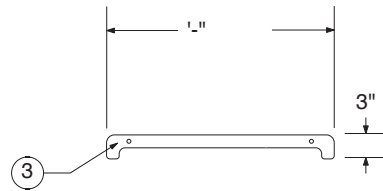

Seat Side view

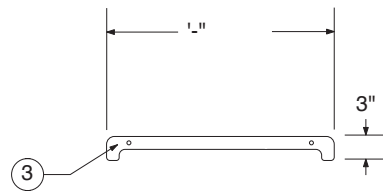

Front View - perf

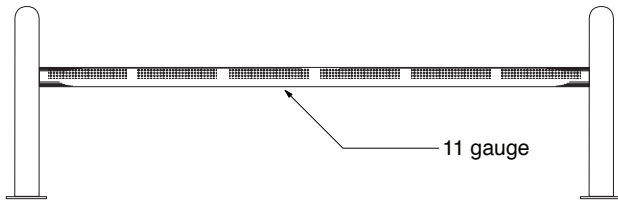

Side view

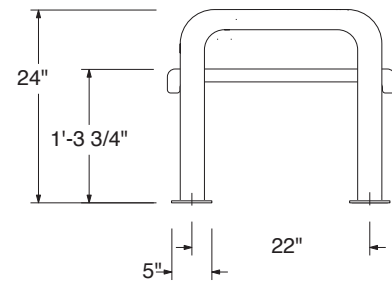

Front View - expanded

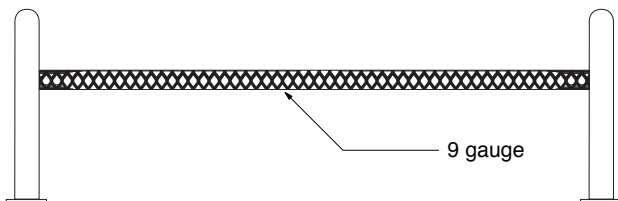



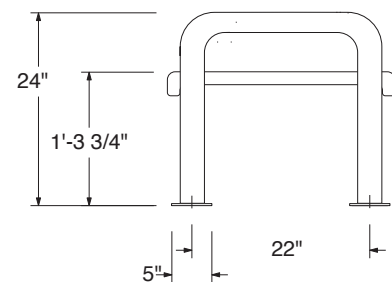



Side view



Available Styles

Quantities (per bench)





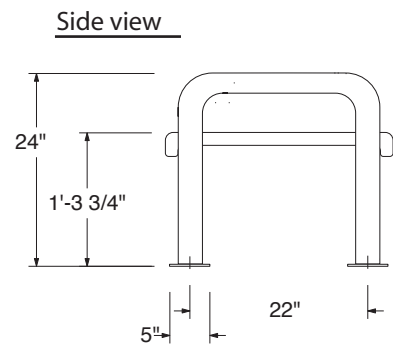
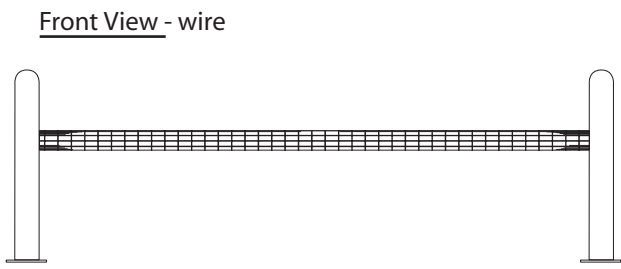
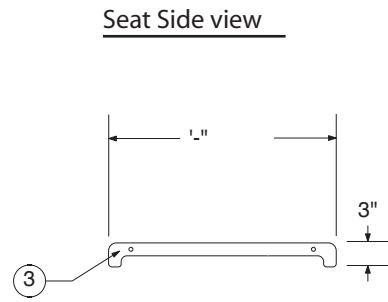
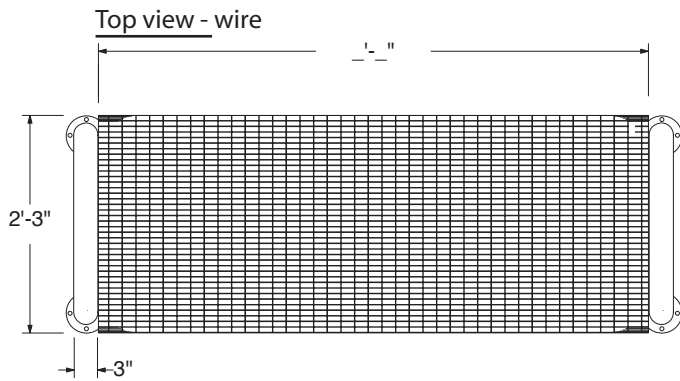

Hardware

	Expanded Metal	1A - Machine Bolt - qty 4		(A) 5/16" Machine head 
	Perforated	1B - 5/16" Washer - qty 4		(B) 5/16" Washer 
	Wire	1C - 5/16" Nut - qty 4		(C) 5/16" Nut 
		2 - Steel Bench Leg w/o Back - qty 2		
		3 - 11 Gage Steel Bench Seat w/o Back - qty 1		
		4 - Steel Bench Leg bars - qty 2		

scale 1/2" = 1'

Roll Formed Bench without Back (Perforated, Expanded, Wire)



Available Styles	Quantities (per bench)	Hardware
 Expanded Metal	1A - Machine Bolt - qty 4 1B - 5/16" Washer - qty 4 1C - 5/16" Nut - qty 4	(A) 5/16" Machine head 
 Perforated	2 - Steel Bench Leg w/o Back - qty 2 3 - 11 Gage Steel Bench Seat w/o Back - qty 1 4 - Steel Bench Leg bars - qty 2	(B) 5/16" Washer 
 Wire		(C) 5/16" Nut 

scale 1/2" = 1'